



RPC 8LGA

Regolatore automatico del fattore di potenza

Manuale utente

Automatic power factor controller

User Manual

1	DESCRIZIONE	3
2	FUNZIONE DEI TASTI FRONTALI	3
3	INDICAZIONI SUL DISPLAY	3
4	MODI OPERATIVI.....	3
5	MISURE	4
6	BLOCCO TASTIERA	4
7	ESPANDIBILITÀ	4
8	PORTA DI PROGRAMMAZIONE IR.....	5
9	IMPOSTAZIONE PARAMETRI	5
10	IMPOSTAZIONE RAPIDA TA	6
11	TABELLA DEI PARAMETRI.....	6
12	ALLARMI.....	9
13	MENU FUNZIONI.....	9
14	MENU COMANDI.....	9
15	UTILIZZO DELLA CHIAVETTA WI-FI (CX02).....	10
16	INSTALLAZIONE	10
17	INFORMAZIONI E ASSISTENZA TECNICA	10
1	DESCRIPTION	11
2	FRONT KEYBOARD	11
3	DISPLAY INDICATIONS	11
4	OPERATING MODES	11
5	MEASURES	12
6	KEYPAD LOCK	12
7	EXPANDABILITY	12
8	IR PROGRAMMING PORT	13
9	PARAMETER SETTING.....	13
10	RAPID CT SETUP	14
11	PARAMETER TABLE	15
12	ALARMS	17
13	FUNCTION MENU	17
14	COMMANDS MENU	18
15	WI-FI DONGLE USE (CX02).....	18
16	INSTALLATION	18
17	INFORMATION & SERVICE.....	18
SCHEMI DI COLLEGAMENTO / WIRING DIAGRAMS		19
MORSETTI / TERMINALS.....		21
DIMENSIONI E FORATURA / DIMENSIONS & CUTOUT [MM]		21
CARATTERISTICHE TECNICHE / TECHNICAL CHARACTERISTICS.....		21

ATTENZIONE!

Leggere attentamente il manuale prima dell'installazione o dell'utilizzo.

Questo apparecchio deve essere installato da personale qualificato, nel rispetto delle vigenti normative, allo scopo di evitare danni o pericoli per persone o cose. Prima di qualsiasi intervento sullo strumento, togliere tensione dagli ingressi di misura e di alimentazione e cortocircuitare il trasformatore di corrente. Il costruttore non si assume responsabilità in caso di utilizzo improprio del dispositivo. I prodotti descritti in questo documento sono suscettibili di alterazioni o modifiche in qualsiasi momento e senza preavviso. Le descrizioni e i dati riportati non possono pertanto avere alcun valore contrattuale. Un dispositivo di interruzione deve essere installato in stretta vicinanza dell'apparecchio ed essere facilmente raggiungibile da parte dell'operatore. Il dispositivo deve essere marchiato come il dispositivo di interruzione dell'apparecchio (IEC EN 61010-1).

WARNING!

Carefully read the manual before the installation or use.

This device must be installed by qualified personnel, in compliance with current rules and regulations, in order to avoid damages or safety hazards for people and belongings. Before any maintenance operation on the device, cut off the voltage from measuring and supply inputs and short-circuit the Current Transformer input terminals. The Manufacturer shall not be held liable in case of incorrect use of the device.

Products illustrated herein are subject to alteration and changes at any moment and without prior notice. Therefore, technical data and descriptions in the document do not have any contractual value. An interrupting device must be installed close by the equipment and within easy reach of the operator.

The device must be marked as the disconnecting device of the equipment (IEC EN 61010-1).

1 DESCRIPTION

- Automatic power factor controller.
- Flush-mount, standard 144x144mm housing.
- Backlit LCD screen.
- 8 relays, expandable to 14 max.
- 5 navigation keys for function and settings.
- Alarm messages in 6 languages.
- Expansion bus with 2 slot expansion modules:
 - RS232, RS485, USB Ethernet communications interface.
 - Additional relay outputs.
- High accuracy TRMS measurements.
- Wide selection of electrical measures, including voltage and current THD with harmonic analysis up to 15th order.
- Voltage input separated from power supply, suitable for VT connection in medium voltage applications.
- Wide-range power supply (100-440VAC).
- Front optical programming interface: galvanically isolated, high speed, USB and WIFI dongle compatible.
- Programming from front panel or from PC.
- 2-level password protection for settings.
- Backup copy of original commissioning settings.
- Built-in temperature sensor.

2 FRONT KEYBOARD

- MODE** key Used to select among available measurements. Used also to access programming menus.
- ▼ ▲** keys Used to set values and to select steps.
- ↔** key Used to select automatic operating mode.
- 👉** key Used to select manual operating mode.

3 DISPLAY INDICATIONS

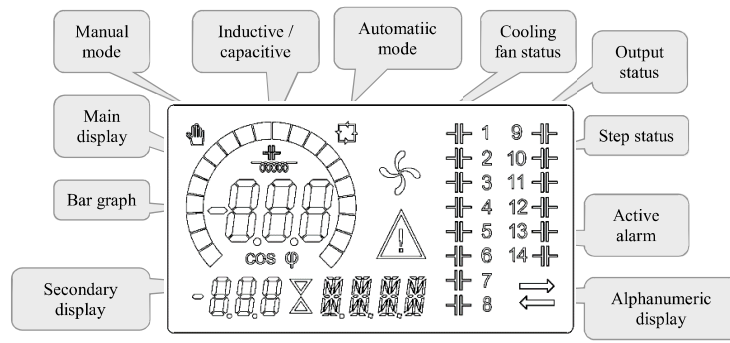

4 OPERATING MODES

4.1 MAN AND AUT MODES

The icons AUT and MAN indicate the operating mode automatic or manual. To change the mode, press and hold the **↔** or **👉** key for 1 second. The operating mode remains stored even after removing and reapplying the power supply voltage.

4.2 MAN MODE

When the unit is in manual mode, you can select one of the steps and manually connected or disconnect it. In addition to the specific icon, the alphanumeric display shows MAN in order to highlight the manual mode condition. Press **MODE** to view the other measurements as usual. While the display shows MAN, it is possible to select the step to be switched on or off. To select a step, use the **▲** or **▼** keys. The selected step will flash quickly. Press **MODE** to activate or deactivate the selected step. If the selected step has not yet exhausted the reconnection time, the **👉** icon will flash to indicate that the transaction has been accepted and will be conducted as soon as possible. Manual configuration of the steps is maintained even when the power supply voltage is removed. When the power returns, the original state of the steps is restored.

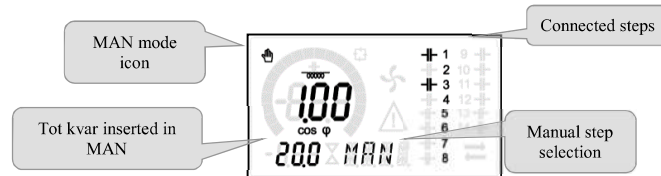

▲ ▼ : Select step - **MODE** : Change step status

4.3 AUT MODE

In automatic mode, the controller calculates the optimum configuration of capacitor steps in order to reach the set $\cos\phi$. The selection criteria takes into account many variables such as: the power of each step, the number of operations, the total time of use, the reconnection time, etc. The controller displays the imminent connection or disconnection of the steps with the flashing of their identification number (left). The flashing can last in cases in which the insertion of a step is not possible due to the reconnection time

(discharge time of the capacitor). The device initiates automatic corrections when there is an average reactive power request (delta-kvar) higher than 50% of the smallest step, and the measured $\cos\phi$ is different from the setpoint.

5 MEASURES

The RPC 8LGA controller provides a set of measurements displayed on the alphanumeric display, in conjunction with the current $\cos\phi$ that is always displayed on the main display. Press the **MODE** key to scroll through the measures in rotation. After 30 seconds without pressing any buttons, the display automatically returns to the default measurement defined by P.47. If P.47 is set on the ROT, then the measures rotate automatically every 5 seconds. At the bottom of the list of measures it is possible to set the setpoint of the $\cos\phi$, acting on the same value set with P.19. Below is a table with the measurements displayed.

MEASURE	ICON	DESCRIPTION
Delta-kvar	<i>Akvar</i>	kvars needed to reach the $\cos\phi$ setpoint. If delta-kvar is positive capacitors need to be inserted, if negative to be disconnected.
▼	<i>kvar</i>	Total kvar of the plant.
▲	<i>ASTEP</i>	Number of equal steps to achieve the target power factor.
MODE		
Voltage	<i>V</i>	RMS voltage of the plant current.
▼	<i>VHI</i>	Maximum voltage value measured.
MODE		
Current	<i>A</i>	RMS current of the plant voltage.
▼	<i>AHI</i>	Maximum current value measured.
MODE		
Average PF	<i>WPF</i>	Weekly average power factor.
▼	<i>PF</i>	Instantaneous total power factor.
MODE		
THD cap.	<i>THdC</i>	Capacitors total harmonic distortion (THD) in current.
▼	<i>TC HI</i>	Maximum THD value measured.
MODE		
Temperature	<i>°C °F</i>	Temperature of internal sensor.
▼	<i>°CHI °FHI</i>	Maximum temperature value measured.
MODE		
Voltage THD	<i>THDV</i>	Total harmonic distortion % (THD) of plant voltage.
▼ ▲	<i>VH02... ..VH15</i>	% voltage harmonic content from 2.nd up to 15.th order
MODE		
Current THD	<i>THDI</i>	Total harmonic distortion % (THD) of plant current.
▼ ▲	<i>IH02... ..IH15</i>	% Current harmonic content from 2.nd up to 15.th order
MODE		
$\cos\phi$ setpoint	<i>IND</i>	Setting of desired $\cos\phi$ setpoint (same as P.19).
▼ ▲	<i>CAP</i>	
MODE		
Step power	<i>%</i>	① Step residual power, as a percentage of the set rated power.
▼ ▲		
MODE		
Step counter	<i>OPC</i>	① Operation counter of the step.
▼ ▲		
MODE		
Step hours	<i>H</i>	① Hour meter of the step insertion.
▼ ▲		

① These measures are shown only if the Step trimming function is enabled (P.25=ON) and the advanced password is enabled and entered.

6 KEYPAD LOCK

A function to exclude all modification to operating parameters can be enabled; measurement viewing is still provided in any case. To lock and unlock the keypad, press and keep the **MODE** key pressed. Then press the ▲ key three times and the ▼ key twice and after that release **MODE**. The display will show **LOC** when the keypad is locked and **UNL** when it is unlocked. When the lock is enabled, it is not possible to make the following operations:

- Operation between automatic and manual mode
- Access to set-up menus
- Change of $\cos\phi$ set-point

By attempting to conduct the above operations, the display will view **LOC** to indicate the locked keypad state.

7 EXPANDABILITY

Thanks to expansion bus, the RPC 8LGA can be expanded with one expansion series module.

The supported expansion modules can be grouped in the following categories:

- additional steps
- communication modules
- digital I/O modules

To insert an expansion module:

- remove the power supply to RPC 8LGA regulator.
- remove the protecting cover of the expansion slot.

- insert the upper hook of the expansion module into the fixing hole on the top of the expansion slot.
- rotate down the module body, inserting the connector on the bus.
- push until the bottom clip snaps into its housing.

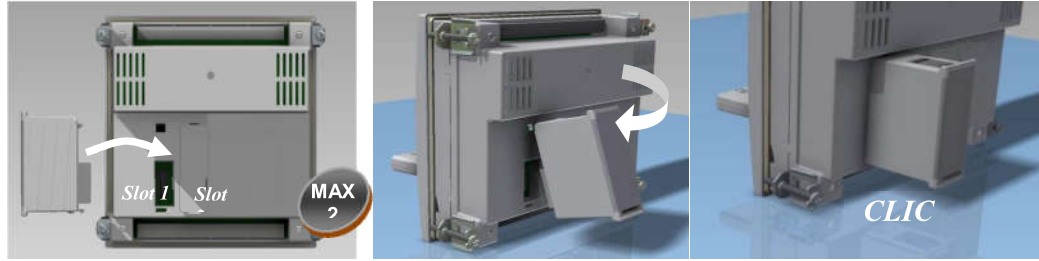

When the RPC 8LGA regulator is powered on, it automatically recognises the expansion module that have been mounted. The expansion modules provide additional resources that can be used through the dedicated setup menus. The setup menus related to the expansions are always accessible, even if the expansion modules are not physically fitted. The following table indicates which models of expansion modules are supported:

MODULE TYPE	CODE	FUNCTION
ADDITIONAL STEPS	OUT 2 NO	2 STEP RELAYS
	OUT 3 NO	3 STEP RELAYS'
COMMUNICATION	COM USB	USB
	COM 232	RS-232
	COM 485	RS-485
	WEB ETH	ETHERNET

8 IR PROGRAMMING PORT

The parameters of the RPC 8LGA regulator can be configured through the front optical port, using the IR-USB programming dongle, or with the IR-WiFi dongle. This programming port has the following advantages:

- Allows for configuring and servicing the RPC 8LGA regulator without having to access the rear of the device or having to open the electrical panel.
- It is galvanically isolated from the internal circuits of the RPC 8LGA regulator, guaranteeing the greatest safety for the operator.
- High speed data transfer.
- IP54 front panel protection.
- Limits the possibility of unauthorized access with device configuration since it is necessary to have the IR-USB or IR-WI-FI dongles.

Simply hold the dongle up to the front panel, connecting the plugs to the relevant connectors, and the device will be acknowledged as shown by the LINK LED on the programming dongle flashing green.



USB programming dongle



WIFI programming dongle

9 PARAMETER SETTING

9.1 SETUP VIA PC

The *PFC Remote monitoring* software can be used to transfer (previously programmed) set-up parameters from the RPC 8LGA regulator to the hard drive of the PC and vice versa. The parameter may be partially transferred from the PC to the RPC 8LGA regulator, transferring only the parameters of the specified menus.

9.2 SETUP VIA THE FRONT PANEL

To access the programming menu (setup).

To enter parameter programming the unit must be in TEST mode (first programming)

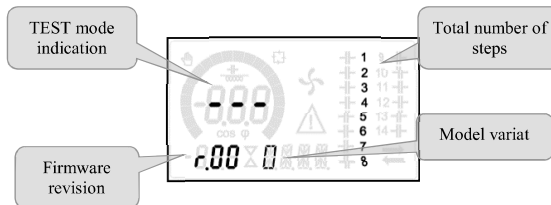

or in MAN mode

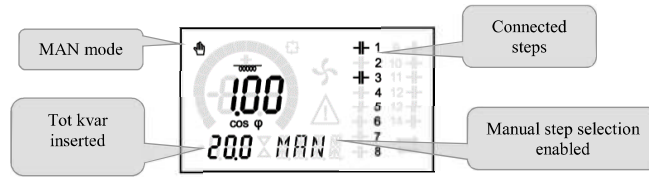

From the normal measurement display, press and hold **MODE** for 3 seconds to recall the main menu. **SET** is displayed on the main display.

If you have set the password (P.21 = ON) instead of **SET** the display shows **PAS** (password entry request). Set the numeric password using **▲ ▼** and then press **↵** to move to next digit. If the password is correct the unit will show **OK U** or **OK A** depending on the entered password is user or the advanced level. The password can be defined with parameters P.22 and P.23. Factory default is **001** and **002** respectively. If the entered password is wrong the unit will show **ERR**. After having entered the password, the access is enabled until the unit is re-initialized or for 2 minutes without pressing any key. After having entered the password, repeat the procedure to access the parameter setting.

Press **▲ ▼** to select the desired submenu (**BAS** → **ADV** → **ALA** ...) that is shown on the alphanumeric display.



The following table lists the available submenus:

COD	DESCRIPTION
BAS	Access to Base menu
ADV	Accesso to Advanced menu
ALA	Accesso to Alarm menu
CMD	Access to Command menu
CUS	Access to Custom menu
SAVE	Exits saving modifications.
EXIT	Exits without saving (cancel)

Press **↵** to access the submenu. When you are in a submenu, the main display shows the code of the selected parameter (eg **P.01**), while the numeric/alphanumeric displays at the bottom of the screen shows the parameter value and / or description. Press **↵** to advance in the selection of items (such as scroll through parameters **P.01** → **P02** → **P03...**), or press **MODE** to go back to the previous parameter. While a parameter is selected, with **▲ ▼** you can increase/decrease its value.

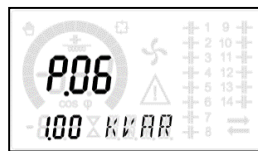

Once you reach the last parameter of the menu, by pressing **↵** once more will return you to the submenu selection. Using **▲ ▼** select **SAVE** to save the changes or **EXIT** to cancel.

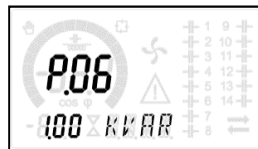

Alternatively, from within the programming, holding **↵** for three seconds will save the changes and exit directly.

If the user does not press any key for more than 2 minutes, the system leaves the setup automatically and goes back to normal viewing without saving the changes done on parameters (like **EXIT**).

Note A backup copy of the setup data (settings that can be modified using the keyboard) can be saved in the eeprom memory of the RPC 8LGA regulator. This data can be restored when necessary in the work memory. The data backup 'copy' and 'restore' commands can be found in the **Commands menu**.

10 RAPID CT SETUP

When the CT value is not known and only used at the moment of the installation, the P.01 parameter for CT primary can remain set at OFF while all the others can be programmed. In this case, during the system installation and once the controller is powered up, the display will show a flashing CT (Current Transformer). By pressing **▲ ▼** the CT primary can be set directly. Once programmed, press **↵** to confirm. The unit will store the setting into P.01, and directly restart in automatic mode.



11 PARAMETER TABLE

Below are listed all the programming parameters in tabular form. For each parameter are indicated the possible setting range and factory default, as well as a brief explanation of the function of the parameter. The description of the parameter shown on the display can in some cases be different from what is reported in the table because of the reduced number of characters available. The parameter code can be used however as a reference.

Note The parameters shown in the table with a shaded background are **essential** to the operation of the system, thus they represent the minimum programming required for operation.

11.1 BASE MENU

COD	DESCRIPTION	PSW	UOM	DEF	RANGE
P.01	CT primary	Usr	A	OFF	OFF / 1...10.000
P.02	CT secondary	Usr	A	5	1 / 5
P.03	CT read phase	Usr		L1	L1 / L2 / L3
P.04	CT wiring polarity	Usr		Aut	Aut / Dir/Inv
P.05	Voltage read phase	Usr		L2-L3	L1-L2 / L2-L3 / L3-L1 L1-N / L2-N / L3-N
P.06	Smallest step power	Usr	Kvar	1.00	0.10 ... 10000
P.07	Rated installation voltage	Usr	V	400V	50 ... 50000
P.08	Nominal frequency	Usr	Hz	Aut	Aut / 50Hz / 60Hz / Var
P.09	Reconnection time	Adv	sec	60	1 ... 30000
P.10	Sensitivity	Usr	sec	60	1 ... 1000
P.11	Step 1 function	Usr		OFF	OFF / 1...32 / ON / NOA / NCA / FAN / MAN / AUT / A01...A12
P.12	Step 2 function	Usr		OFF	=
P.13	Step 3 function	Usr		OFF	=
P.14	Step 4 function	Usr		OFF	=
P.15	Step 5 function	Usr		OFF	=
P.16	Step 6 function	Usr		OFF	=
P.17	Step 7 function	Usr		OFF	=
P.18	Step 8 function	Usr		OFF	=
P.19	Cos-phi setpoint	Usr		0.95 IND	0.50 Ind – 0.50 Cap

P.01 The value of the primary current transformer. Example: with CT 800/5 set 800. If set to OFF, after the power-up the device will prompt you to set the CT and allow direct access to this parameter.

P.02 Value of the secondary of the current transformers. Example: with CT 800/5 set 5.

P.03 It defines on which phase the device reads the current signal. The wiring of current inputs must match the value set for this parameter. Supports all possible combinations of parameter P.05.

P.04 Reading the connection polarity of the CT.

AUT = Polarity is automatically detected at power up. Can only be used when working with only one CT and when the system has no generator device.

Dir = Automatic detection disabled. Direct connection.

Inv = Automatic detection disabled. Reverse wiring

P.05 Defines on which and on how many phases the device reads the voltage signal. The wiring of voltage inputs must match the setting for this parameter. Supports all possible combinations of parameter P.03.

P.06 Value in kvar of the smallest step installed (equivalent to the step weight 1). Rated power of the capacitor bank provided at the rated voltage specified in P.07 (example: step 10kvar-460V supplied 400V → 10 x (400)²/(460)² → set 7,5kvar).

P.07 Installation rated voltage, which is delivered in specified power P.06.

P.08 Working frequency of the system:

Aut = automatic selection between 50 and 60 Hz at power on.

50Hz = fixed to 50 Hz.

60Hz = fixed to 60 Hz.

Var = variable, measured continuously and adjusted.

P.09 Minimum time that must elapse between the disconnection of one step and the subsequent reconnection both in MAN or AUT mode. During this time the number of the step on the main page is blinking.

P.10 Connection sensitivity. This parameter sets the speed of reaction of the controller. With small values of P.10 the regulation is fast (more accurate around the setpoint but with more step switchings). With high values instead we'll have slower reactions of the regulation, with fewer switchings of the steps. The delay time of the reaction is inversely proportional to the request of steps to reach the setpoint: waiting time = (sensitivity / number of steps required).

Example: setting the sensitivity to 60s, if you request the insertion of one step of weight 1 are expected 60s (60/1 = 60). If instead serve a total of 4 steps will be expected 15s (60/4 = 15).

P11 ... P18 Function of output relays 1 ... 8:

OFF = Not used .

1 .. 32 = Weight of the step. This relay drives a bank of capacitors which power is n times (n = 1...32) the smallest power defined with parameter P.06.

ON = Always on.

NOA = Alarm normally de-energized. The relay is energized when any alarm with the Global alarm property arises.

NCA = Alarm normally energized. The relay is de-energized when any alarm with the Global alarm property arises.

FAN = The relay controls the cooling fan.

MAN = Relay is energized when device is in MAN mode.

AUT = Relay is energized when device is in AUT mode.

A01 ... A12 = The relay is energized when the alarm specified is active.

P.19 Setpoint (target value) of the cosφ. Used for standard applications.

P.20 Language of scrolling alarm messages.

11.2 ADVANCED MENU

COD	DESCRIPTION	PSW	UOM	DEF	RANGE
P.21	Password enable	Adv		OFF	OFF / ON
P.22	User password	Usr		001	0-999
P.23	Advanced password	Adv		002 (*)	0-999
P.24	Wiring type	Usr		3PH	3PH three-phase 1PH single-phase
P.25	Step trimming	Usr		ON	ON Enabled OFF Disabled
P.26	Setpoint clearance +	Usr		0.00	0 – 0.10
P.27	Setpoint clearance -	Usr		0.00	0 – 0.10
P.28	Step insertion mode	Usr		STD	STD Standard LIN Linear
P.29	Cogeneration cosφ setpoint	Usr		OFF	OFF / 0.50 IND – 0.50 CAP

COD	DESCRIPTION	PSW	UOM	DEF	RANGE
P.30	Disconnection sensitivity	Usr	sec	OFF	OFF / 1 – 600
P.31	Step disconnection passing in MAN	Usr		OFF	OFF Disabled ; ON Enabled
P.32	Capacitor current overload alarm threshold	Adv	%	50	OFF / 0...150
P.33	Capacitor overload immediate disconnection threshold	Adv	%	83	OFF / 0.. 200
P.34	VT primary	Usr	V	OFF	OFF / 50-50000
P.35	VT secondary	Usr	V	100	50-500
P.36	Temperature UoM	Usr		°C	°C °Celsius ; °F °Fahrenheit
P.37	Fan start temperature	Adv	°	25	0 ... 212
P.38	Fan stop temperature	Adv	°	20	0 ... 212
P.39	Temperature alarm threshold	Adv	°	55	0 ... 212
P.41	Maximum voltage alarm threshold	Adv	%	110	OFF / 90...150
P.42	Minimum voltage alarm threshold	Adv	%	90	OFF / 60...110
P.43	THD V alarm threshold	Adv	%	6	OFF / 1...250
P.44	THD I alarm threshold	Adv	%	12	OFF / 1...250
P.45	Maintenance interval	Adv	h	9000 8760(**)	1 - 30000
P.46	Bar-graph function	Usr		Kvar ins/tot	Kvar ins/tot / Corr att/nom / Delta kvar ins/tot
P.47	Default auxiliary measure	Usr		Week TPF	Deltakvar / V / A / Week TPF / Cap. Current / Temp / THDV / THDI / ROT
P.48	Backlight flashing on alarm	Usr		OFF	OFF / ON
P.49	Serial node address	Usr		01	01-255
P.50	Serial speed	Usr	bps	9.6k	1.2k / 2.4k / 4.8k / 9.6k / 19.2k / 38.4k
P.51	Data format	Usr		8 bit – n	8 bit, no parity / 8 bit, odd / 8bit, even / 7 bit, odd / 7 bit, even
P.52	Stop bits	Usr		1	1-2
P.53	Protocol	Usr		Modbus RTU	Modbus RTU / Modbus ASCII
P.54	Number of insertions for maintenance	Adv	kent	OFF	OFF / 1...60
P.55	Step 9 function	Usr		OFF	=
P.56	Step 10 function	Usr		OFF	=
P.57	Step 11 function	Usr		OFF	=
P.58	Step 12 function	Usr		OFF	=
P.59	Step 13 function	Usr		OFF	=
P.60	Step 14 function	Usr		OFF	=

- P.21 If set to OFF, password management is disabled and anyone has access to the settings and commands menu.
- P.22 With P.21 enabled, this is the value to specify for activating user level access. See Password access chapter.
- P.23 As for P.22, with reference to Advanced level access. (*) **Available value only if the controller is not installed on the ICAR cabinet**
- P.24 Number of phases of the power correction panel.
- P.25 Enables the measurement of the actual power of the step, performed each time they are switched in. The measure is calculated, as the current measurement is referred to the whole load of the plant. The measured power of the steps is adjusted (trimmed) after each switching and is displayed on the step life statistic page. When this function is enabled, a 15 sec pause is inserted between the switching of one step and the following, necessary to measure the reactive power variation.
- P.26 – P.27 Tolerance around the setpoint. When the cosφ is within the range delimited by these parameters, in AUT mode the device does not connect/disconnect steps even if the delta-kvar is greater than the smallest step.
- P.28 Selecting mode of steps insertion.
Standard mode - Normal operation with free selection of the steps
Linear mode - the steps are connected in progression from left towards right only following the step number and according to the LIFO (Last In First Out) logic. The controller will not connect a step when the system steps are of different ratings and by connecting the next step, the set-point value would be exceeded.
- P.29 Setpoint used when the system is generating active power to the supplier (with negative active power / power factor).
- P.30 Disconnection sensitivity. Same as the previous parameter but related to disconnection. If set to OFF the disconnection has the same reaction time of connection set with the previous parameter.
- P.31 If set to ON, when switching from AUT mode to MAN mode, steps are disconnected in sequence.
- P.32 Trip threshold for the capacitors overload protection (alarm A08), that will arise after a integral delay time, inversely proportional to the value of the overload.
Note: You can use this protection only if the capacitors are not equipped with filtering devices such as inductors or similar.
- P.33 Threshold beyond which the integral delay for tripping of the overload alarm is zeroed, causing the immediate intervention of the A08 alarm.
- P.34 – P.35 Data of VTs eventually used in the wiring diagrams.
- P.36 Unit of measure for temperature.
- P.37 – P.38 Start and stop temperature for the cooling fan of the panel, expressed in the unit set by P.36. The cooling fan is started when the temperature is >= to P.37 and it is stopped when it is < than P.38.
- P.39 Threshold for generation of alarm *A08 Panel temperature too high*.
- P.41 Maximum voltage alarm threshold, referred to the rated voltage set with P.07, beyond which the alarm *A06 Voltage too high* is generated.
- P.42 Undervoltage alarm threshold, referred to the rated voltage set with P.07, below which the alarm *A05 voltage too low* is generated.
- P.43 Maximum installation voltage THD alarm threshold, beyond which the alarm *A10 THDV too high* is generated.
- P.44 Maximum installation current THD alarm threshold beyond which the alarm *A05 voltage too low* is generated.
- P.45 Maintenance interval in hours. When it is elapsed, the alarm *A12 Ordinary maintenance* will be generated. The hour count increments as long as the device is powered. (**)
If the controller is installed on the ICAR cabinet
- P.46 Function of the semi-circular bar-graph.
kvar ins/tot: The bar graph represents the amount of kvar actually inserted, with reference to the total reactive power installed in the panel.
Curr act/nom: Percentage of actual plant current with reference to the maximum current of the CT.
Delta kvar: bar graph with central zero. It repress the positive/negative delta-kvar needed to reach the setpoint, compared to the total kvar installed.
- P.47 Default measure shown on the secondary display. Setting the parameter to **ROT**, the different measures will be shown with a sequential rotation.
- P.48 If set to ON, the display backlight flashes in presence of one or more active alarms.
- P.49 Serial (node) address of the communication protocol.
- P.50 Communication port transmission speed.
- P.51 Data format. 7 bit settings can only be used for ASCII protocol.
- P.52 Stop bit number.
- P.53 Select communication protocol.
- P.54 Defines the number of the step (considering the step that has the highest count) beyond which the maintenance alarm A12 is generated.
- P.55 ... P60 Function of output relays 9...14. See description of parameter.

11.3 ALARM MENU

COD	DESCRIPTION	PSW	UOM	DEF	RANGE
P.61	A01 Alarm enable	Adv		ALA	OFF / ON / ALA / DISC / A+D

COD	DESCRIPTION	PSW	UOM	DEF	RANGE
P.62	A01 alarm delay	Adv		15	0-240
P.63	A01 delay uom	Adv		min	Min / Sec
...
P.94	A12 Alarm enable	Adv		ALA	OFF / ON / ALA / DISC / A+D
P.95	A12 alarm delay	Adv		120	0-240
P.96	A12 delay uom	Adv		sec	Min / Sec

P.61 Enable alarm A01 and defines the behavior of the controller when the alarm is active:

OFF - Alarm disabled

ON - Alarm enabled, only visual

ALA - Alarm enabled, global alarm relay energized (if set)

DISC - Alarm enabled, logoff step

A + D = Alarm relay energized and disconnection of the steps.

Note: When you access the parameters P61, P.64, P67, etc., the auxiliary display shows the relative alarm code.

P.62 Delay alarm A01.

P.63 Unit of delay alarm A01.

P.64 Like P.61 for alarm A02.

P.65 Like P.62 for alarm A02.

P.66 Like P.63 for alarm A02.

...

P.94 Like P.61 for alarm A12.

P.95 Like P.62 for alarm A12.

P.96 Like P.63 for alarm A12.2.

12 ALARMS

When an alarm is generated, the display will show an alarm icon, the code and the description of the alarm in the language selected. If the navigation keys in the pages are pressed, the scrolling message showing the alarm indications will disappear momentarily, to reappear again after 30 seconds. Alarms are automatically reset as soon as the alarm conditions that have generated them disappear. In the case of one or more alarms, the behaviour of the RPC 8LGA regulator depends on the *properties* settings of the active alarms.

12.1 ALARM DESCRIPTION

COD	ALARM	DESCRIPTION
A01	Undercompensation	In automatic mode, all the available steps are connected but the cosphi is still more inductive than the setpoint.
A02	Overcompensation	In automatic mode, all the steps are disconnected but the cosphi is still more capacitive than the setpoint.
A03	Current too low	The current flowing in the current inputs is lower than minimum measuring range. This condition can occur normally if the plant has no load.
A04	Current too high	The current flowing in the current inputs is higher than the maximum measuring range.
A05	Voltage too low	The measured voltage is lower than the threshold set with P.42.
A06	Voltage too high	The measured voltage is higher than the threshold set with P.41.
A07	Capacitor current overload	The calculated capacitor current overload is higher than threshold set with P.32 and P.33. After the alarm conditions have disappeared, the alarm message remains shown for the following 5 min or until the user presses a key on the front.
A08	Temperature too high	The panel temperature is higher than threshold set with P.39.
A09	No-Voltage release	A no-voltage release has occurred on the line voltage inputs, lasting more than 8ms.
A10	Voltage THD too high	The THD of the plant voltage is higher than the threshold set with P.43.
A11	Current THD too high	The THD of the plant current is higher than the threshold set with P.44.
A12	Ordinary maintenance requested	The maintenance interval set with P.45 has elapsed. To reset the alarm use the command C.01 (see Command menu).

12.2 DEFAULT ALARM PROPERTIES

COD.	DESCRIPTION	ENABLE	ALARM RELAY	DISCONNECTION	DELAY
A01	Undercompensation	●	●		15 min
A02	Overcompensation				120 s
A03	Current too low	●	●	●	30 s
A04	Current too high	●	●		60 s
A05	Voltage too low	●	●		60 s
A06	Voltage too high	●	●	●	15 min
A07	Capacitor current overload	●	●	●	3 min
A08	Temperature too high	●	●	●	60 s
A09	No-Voltage release	●	●	●	0 s
A10	Voltage THD too high	●	●	●	60 s
A11	Current THD too high	●	●	●	60 s
A12	Maintenance requested	●	●		0s

13 FUNCTION MENU

COD	DESCRIPTION	ACC	UOM	DEF	RANGE
F.01	Indirizzo IP	Usr		192.168.1.1	IP1.IP2.IP3.IP4 IP1 0...255 / IP2 0...255 / IP3 0...255 / IP4 0...255
F.02	Subnet mask	Usr		0.0.0.0	SUB1.SUB2.SUB3.SUB4 SUB1 0...255 / SUB2 0...255 / SUB3 0...255 / SUB4 0...255
F.03	Porta IP	Usr		1001	0...9999
F.04	Client/server	Usr		Server	Client/server
F.05	Indirizzo IP remoto	Usr		0.0.0.0	IP1.IP2.IP3.IP4 IP1 0...255 / IP2 0...255 / IP3 0...255 / IP4 0...255
F.06	Porta IP remota	Usr		1001	0...9999
F.07	Indirizzo IP gateway	Usr		0.0.0.0	GW1.GW2.GW3.GW4 GW1 / GW2 / GW3 / GW4

F.01...F.03 TCP-IP coordinates for Ethernet interface application.

F.04 Enabling TCP-IP connection. Server = Awaits connections from a remote client. Client = Establishes a connection to the remote server

F.05...F.07 Coordinates for the connection to the remote server when F.04 is set to client.

14 COMMANDS MENU

The commands menu allows executing some occasional operations like reading peaks resetting, counters clearing, alarms reset, etc. If the Advanced level password has been entered, then the commands menu allows executing the automatic operations useful for the device configuration. The following table lists the functions available in the commands menu, divided by the access level required.

With controller in MAN mode, press **MODE** for 5s. Press **▲** to select **CMD**. Press **↵** to access the *Commands menu*. Select the desired command with **↵**.

Press and hold for three seconds **▲** if you want to execute the selected command. The RPC 8LGA regulator shows **OK?** with a countdown. If you press and hold **▲** until the end of the countdown the command is executed, while if you release the key before the end, the command is canceled.

COD.	COMMAND	PSW	DESCRIPTION
C01	RESET MAINTENANCE	Usr	Reset maintenance service interval.
C02	RESET STEP COUNT	Adv	Reset step operation counters.
C03	RESET STEP TRIMMING	Adv	Reload originally programmed power into step trimming.
C04	RESET STEP HOURS	Adv	Reset step operation hour meters.
C05	RESET MAX VALUES	Adv	Reset maximum peak values.
C06	RESET WEEKLY TPF	Usr	Resets weekly total power factor history.
C07	SETUP TO DEFAULT	Adv	Resets setup programming to factory default.
C08	SETUP BACKUP	Adv	Makes a backup copy of user setup parameters settings.
C09	SETUP RESTORE	Usr	Reloads setup parameters with the backup of factory settings.

15 WI-FI DONGLE USE (CX02)

The WI-FI dongle offers WI-FI access point capability for connection to PC, Tablet or Smartphone. In addition to this function it also offer the possibility to store and transfer a block of data from/to the RPC 8LGA regulator. Insert the interface WI-FI into the IR port of RPC 8LGA regulator on the front plate. Switch WI-FI dongle on by pressing the button for 2 sec. Wait until the **LINK** LED becomes orange flashing. Press 3 times consecutively and fast the dongle button. At this point the display of the RPC 8LGA regulator shows the first of the 6 possible commands (D1...D6). Press **▲▼** to select the desired command. Press **↵** to execute the selected command.

The unit will prompt for a confirmation (**OK?**). Press once again **↵** per confermare, or **MODE** to cancel. The following table lists the possible commands:

CODE	COMMAND	DESCRIPTION
D1	SETUP DEVICE → CX02	Copies Setup settings from RPC 8LGA regulator to WI-FI dongle.
D2	SETUP CX02 → DEVICE	Copies Setup settings from WI-FI dongle to RPC 8LGA regulator.
D3	CLONE DEVICE → CX02	Copies Setup settings and working data from RPC 8LGA regulator to WI-FI dongle.
D4	CLONE CX02 → DEVICE	Copies Setup settings and working data from WI-FI dongle to RPC 8LGA regulator.
D5	INFO DATA CX02	Shows information about data stored into WI-FI dongle.
D6	EXIT	Exits from dongle menu.

16 INSTALLATION

RPC 8LGA controller is designed for flush-mount installation. With proper mounting, it guarantees IP54 front protection.

Insert the device into the panel hole, making sure that the gasket is properly positioned between the panel and the device front frame. From inside the panel, for each four of the fixing clips, position the clip in its square hole on the housing side, then move it backwards in order to position the hook.

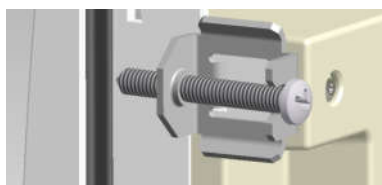

Repeat the same operation for the four clips.

Tighten the fixing screw with a maximum torque of 0,5Nm.

In case it is necessary to dismount the system, repeat the steps in opposite order.

For the electrical connection see the wiring diagrams in the dedicated chapter and the requirements reported in the technical characteristics table.

17 INFORMATION & SERVICE

ICAR by ORTEA NEXT
ORTEA S.p.A
Via dei Chiosi 21 20873 Cavenago B.za (MB) – Italy
Tel. +39 02 9591 7800
www.next.ortea.com
 Technical service: ortea@ortea.com

SCHEMI DI COLLEGAMENTO / WIRING DIAGRAMS



ATTENZIONE!

Togliere sempre tensione quando si opera sui morsetti.

WARNING!

Disconnect the line and the supply when operating on terminals.

17.1 INSERIZIONE TRIFASE STANDARD / STANDARD THREE-PHASE CONNECTION

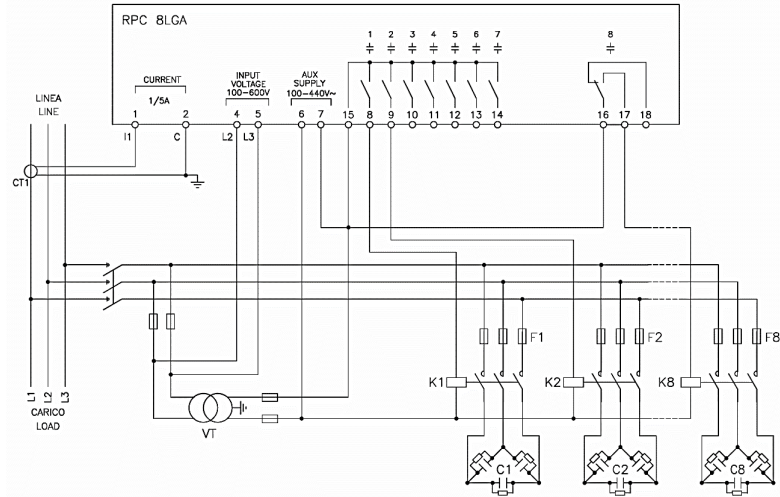

INSERIZIONE TRIFASE STANDARD (default) Configurazione di default per applicazioni standard	
Misura tensione	1 misura di tensione concatenata L2-L3
Misura corrente	Fase L1
Angolo di sfasamento	Fra V (L2-L3) e I (L1) $\Rightarrow 90^\circ$
Misura sovraccarico condensatori	1 misura calcolata su L2-L3
Impostazione parametri	P.03 = L1 - P.05 = L2-L3 - P.24 = 3PH
NOTE	
Per inserzione trifase, l'ingresso voltmetrico deve essere connesso tra due fasi; il T.A. di linea deve essere inserito sulla rimanente fase. La polarità dell'ingresso amperometrico è ininfluente.	

THREE-PHASE STANDARD CONNECTION (default) Default wiring configuration for standard applications	
Voltage measure	1 ph-to-ph voltage reading L2-L3
Current measure	L1 phase
Phase angle offset	Between V (L2-L3) and I (L1) $\Rightarrow 90^\circ$
Capacitor overload current measure	1 reading calculated on L2-L3
Parameter setting	P.03 = L1 - P.05 = L2-L3 - P.24 = 3PH
NOTES	
For three-phase connection, the voltage input must be connected phase to phase; the current transformer must be connected on the remaining phase. The polarity of the current/voltage input is indifferent.	

17.2 INSERZIONE MONOFASE / SINGLE-PHASE CONNECTION

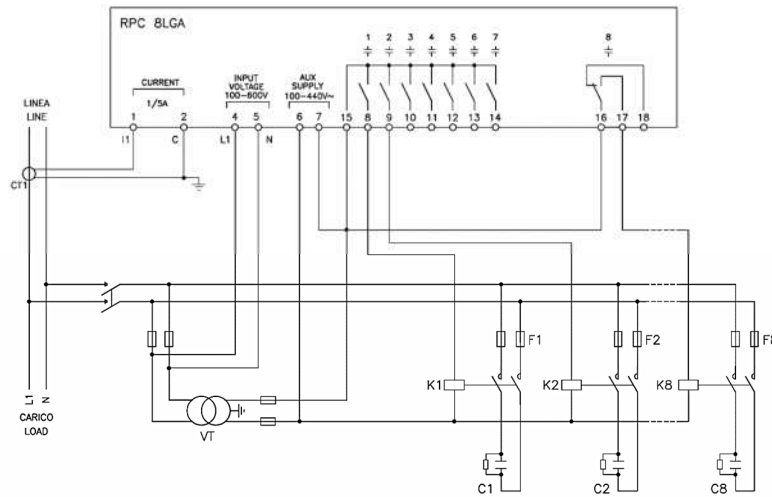

INSERZIONE MONOFASE Configurazione per applicazioni con rifasamento monofase	
Misura tensione	1 misura di tensione di fase L1-N
Misura corrente	Fase L1
Angolo di sfasamento	Fra V (L1-N) e I (L1) $\Rightarrow 0^\circ$
Sovraccarico condensatori	1 misura calcolata su L1-N
Impostazione parametri	P.03 = L1 - P.05 = L1-N - P.24 = 1PH
NOTE	
IMPORTANT! La polarità dell'ingresso amperometrico è ininfluente.	
SINGLE-PHASE CONNECTION Wiring configuration for single-phase applications	
Voltage measure	1 phase voltage reading L1-N
Current measure	L1 phase
Phase angle offset	Between V (L1-N) and I (L1) $\Rightarrow 0^\circ$
Capacitor overload current measure	1 reading calculated on L1-N
Parameter setting	P.03 = L1 - P.05 = L1-N - P.24 = 1PH
NOTES	
IMPORTANT! The polarity of the current/voltage input is indifferent.	

17.3 INSERZIONE SU MT / CONFIGURATION IN MV

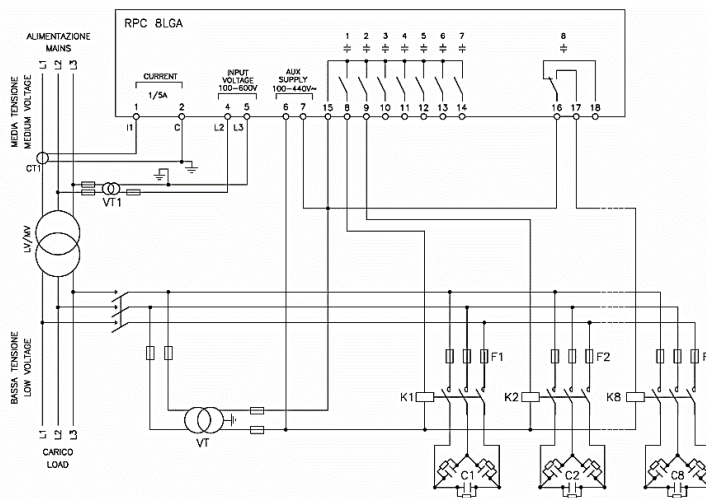

INSERZIONE CON MISURE SU MT E RIFASAMENTO IN BT		
Misura tensione	1 misura di tensione concatenata L2-L3 su media tensione	
Misura corrente	Fase L1 su media tensione	
Angolo di sfasamento	90°	
Impostazione parametri	P.03 = L1 P.05 = L2-L3 P.24 = 3PH	P34 = Primario VT1 P35 = Secondario VT1
CONFIGURATION WITH MV MEASUREMENT AND CORRECTION		
Voltage measure	1 ph-to-ph voltage reading L2-L3 on MV side	
Current measure	L1 phase on MV side	
Phase angle offset	90°	
Parameter setting	P.03 = L1 P.05 = L2-L3 P.24 = 3PH	P.34 = VT1 primary P.35 = VT1 secondary

MORSETTI / TERMINALS

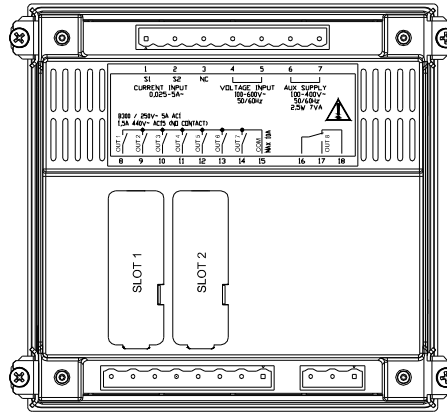

DIMENSIONI E FORATURA / DIMENSIONS & CUTOUT [mm]

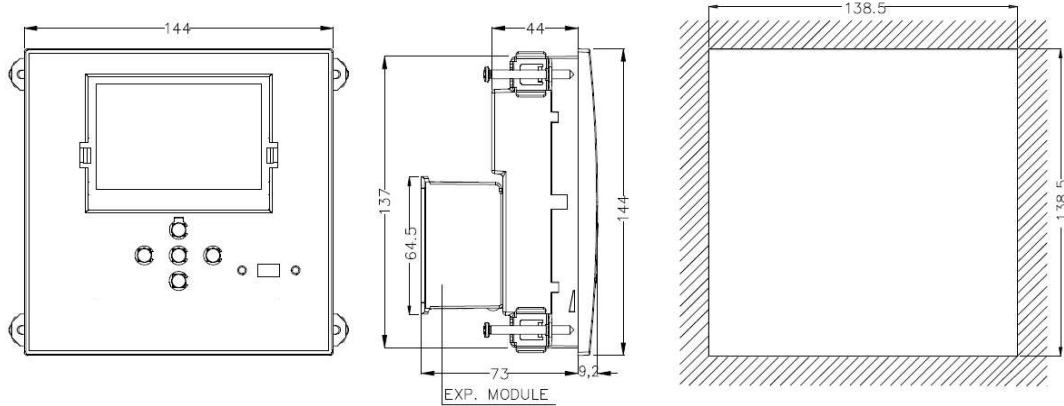

CARATTERISTICHE TECNICHE / TECHNICAL CHARACTERISTICS

Alimentazione	Supply	
Tensione nominale Us ⓘ	Rated voltage Us ⓘ	100 - 440V~ 110 - 250V=
Limiti di funzionamento	Operating voltage range	90 - 484V~ 93,5 - 300V=
Frequenza	Frequency	45 - 66Hz
Potenza assorbita/dissipata	Power consumption/dissipation	2,5W - 7VA
Rilascio relè alla microinterruzione	No-voltage release	>= 8ms
Tempo di immunità alla microinterruzione	Immunity time for microbreakings	<= 25ms
Fusibili raccomandati	Recommended fuses	F1A (rapidi)
Ingresso voltmetrico	Voltage inputs	
Tensione nominale Ue max	Maximum rated voltage Ue	600VAC
Campo di misura	Measuring range	50...720V
Campo di frequenza	Frequency range	45...65Hz
Tipo di misura	Measuring method	True RMS
Impedenza dell'ingresso di misura	Measuring input impedance	> 15MΩ
Accuratezza misura	Accuracy of measurement	±1% ±0,5 digit
Fusibili raccomandati	Recommended fuses	F1A (rapidi)
Ingressi amperometrici	Current inputs	
Corrente nominale Ie	Rated current Ie	1A~ o 5A~
Campo di misura	Measuring range	5A: 0,025 - 6A - 1A: 0,025 - 1,2A~
Tipo di ingresso	Type of input	TA ext bt / Lv ext CT / TI ext bt 5A max.
Tipo di misura	Measuring method	True RMS
Limite termico permanente	Overload capacity	+20% Ie
Limite termico di breve durata	Overload peak	50A / 1 sec
Accuratezza misura	Accuracy of measurement	± 1% (0,1...1,2In) ±0,5 digit
Autoconsumo	Power consumption	<0,6VA
Precisione misure	Measuring accuracy	
Tensione di linea	Line voltage	±0,5% f.s. ±1digit
Uscite a relè: OUT 1 - 7	Relay output: OUT 1 - 7	
Tipo di contatto	Contact type	7x1 NO+comune contatti/contacts common
Dati d'impiego UL	UL Rating	B300, 5A 250V~ 30V= 1A Pilot Duty, 1,5A 440V~ Pilot Duty
Massima tensione d'impiego	Max rated voltage	440V~
Portata nominale	Rated current	AC1-5A 250V~ AC15-1,5A 440V~
Corrente massima al terminale comune dei contatti	Maximum current at contact common	10A

Durata meccanica / elettrica	Mechanical / electrical duration	1x10 ⁷ / 1x10 ⁵ operazioni / operations
Uscite a relè: OUT 8	Relay output: OUT 8	
Tipo di contatto	Contact type	1 contatto scambio/changeover contact
Dati d'impiego UL	UL Rating	B300, 5A 250V~ 30V= 1A Pilot Duty, 1,5A 440V~ Pilot Duty
Massima tensione d'impiego	Max rated voltage	440V~
Portata nominale	Rated current	AC1-5A 250V~ AC15-1,5A 440V~
Durata meccanica / elettrica	Mechanical / electrical duration	1x10 ⁷ / 1x10 ⁵ operazioni / operations
Tensione di isolamento	Insulation voltage	
Tensione nominale d'isolamento Ui	Rated insulation voltage Ui	600V~
Tensione nomi.di tenuta a impulso Uimp	Rated impulse withstand voltage Uimp	9,5kV
Tensione di tenuta a frequenza d'esercizio	Power frequency withstand voltage	5,2kV
Condizioni di funzionamento	Operating conditions	
Temperatura d'impiego	Operating temperature	-20 - +60°C
Temperatura di stoccaggio	Storage temperature	-30 - +80°C
Umidità relativa	Relative humidity	<80% (IEC/EN 60068-2-78)
Inquinamento ambiente massimo	Maximum pollution degree	Grade 2
Categoria di sovratensione	Overvoltage category	3
Categoria di misura	Measurement category	III
Sequenza climatica	Climatic sequence	Z/ABDM (IEC/EN 60068-2-61)
Resistenza agli urti	Shock resistance	15g (IEC/EN 60068-2-27)
Resistenza alle vibrazioni	Vibration resistance	0.7g (IEC/EN 60068-2-6)
Connessioni	Connections	
Tipo di morsetti	Terminal type	Estraibili / Removable
Sezione conduttori (min e max)	Cable cross section (min... max)	0,2...2,5 mmq (24÷12 AWG)
Dati d'impiego UL	UL Rating: Cable cross section (min... max)	0,75...2.5 mm ² (18-12 AWG)
Sezione conduttori (min e max)		
Coppia di serraggio	Tightening torque	0,56 Nm (5 LBin)
Contenitore	Housing	
Esecuzione	Version	Da incasso / Flash mount
Materiale	Material	Policarbonato / Polycarbonate
Grado di protezione frontale	Degree of protection	IP54 fronte con guarnizione /front with gasket IP20 morsetti/terminals
Peso	Weight	640g
Omologazioni e conformità	Certifications and compliance	
cULus	cULus	In corso/Pending
Conformità a norme	Reference standards	IEC/EN 61010-1, IEC/EN 61000-6-2 IEC/EN 61000-6-4 UL508 e CSA C22.2-N°14
UL Marking		Use 60°C/75°C copper (CU) conductor only AWG Range: 18 - 12 AWG stranded or solid Field Wiring Terminals Tightening Torque: 4.5lb.in Flat panel mounting on a Type 1 enclosure

ⓘ Alimentazione ausiliaria prelevata da un sistema con tensione fase-neutro ≤300V / Auxiliary supply connected to a line with a phase-neutral voltage ≤300V

NOTE:



IMPROVE YOUR POWER QUALITY

ORTEA SpA
Via dei Chiosi, 21
20873 Cavenago Brianza – Milan – ITALY
Tel.: ++39 02 95917800
www.next.orteacom

IL SISTEMA INTEGRATO DI
GESTIONE DI ORTEA SpA
È CERTIFICATO DA LRQA
SECONDO

ORTEA SpA INTEGRATED
MANAGING SYSTEM IS
APPROVED BY **LRQA**
ACCORDING TO:

LE SYSTEME INTEGRE
POUR LA GESTION
D'ORTEA SpA EST
CERTIFIE PAR **LRQA**
SELON :

ISO9001 ISO14001 OHSAS18001

